

4x 8.5mm  
Mounting Holes

max. clamping range  
(max. face thickness)

All measurements in 'mm'

Type	a	b	c
MZW1300/40	40	70	100
MZW1300/150	150	180	210
MZW1300/250	250	280	310
MZW1300/WL	Variable length = max 800mm		

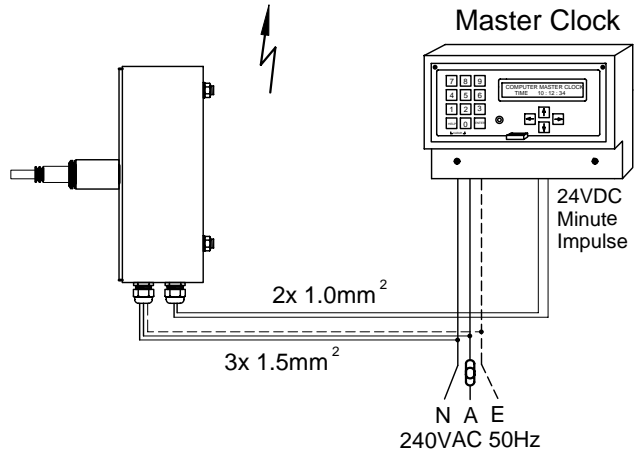

### SPECIFICATIONS

<b>Application:</b>	Outdoor, unprotected hands	<b>Electric Drive:</b>	230VAC 105 VA
<b>Max. Dial Diameter:</b>	1300 mm with light hands	<b>Slave Operation:</b>	230VAC alternating minute impulse, min. 6 sec duration
<b>Motion of Hands:</b>	Creeping minute, creeping hour	<b>Case:</b>	Steel
<b>Gearing:</b>	Brass and stainless steel, self lubricating, maintenance-free	<b>Case Rating:</b>	Dust protected
<b>Second Hand Synchronisation:</b>	Not applicable	<b>Maintenance:</b>	Maintenance free
<b>Manual Time Setting:</b>	With optional on/off switch	<b>Life Expectancy:</b>	25 - 30 years depending on environmental conditions
<b>Shaft Diameter:</b>	Minute: 8mm Hour: 15mm	<b>Second Hand Revolutions:</b>	Not applicable
		<b>Approx. Weight:</b>	5.000 kg

JOB NO.:	DWG NO.:	TITLE: <b>Perrot MZW1300-REM</b> German Long Life Slave Movement for max. 1300mm diameter dials timed by alternating minute impulses	<p>Hertz Electronics Pty Ltd A.B.N. 24 002 885 967</p>
DATE:	SCALE: Not to scale	CLIENT:	
DWN: <b>NM</b>	SIZE: <b>A4</b>	539 GLENMORE ROAD, EDGECLIFF NSW 2027 PH: -61-2 -9363 3029 FAX: -61 -2 -9327 7827 email address: sales@hertzelectronics.com.au hertz web site: WWW.hertzelectronics.com.au	
COPYRIGHT: The drawing remains the property of Hertz Electronics P/L and may not be used, copied, or reproduced, in whole or part in any form without written permission.			